

PART NO.	MATERIAL	COLOR	ADHESIVE
FTH-5-01	NYLON 6/6 (RMS-01)	NATURAL	NONE
FTH-5A-RT			ACRYLIC TAPE (RMS-15), WHITE LINER
FTH-5A1-RT			RUBBER TAPE (RMS-102), BLUE LINER
FTH-5-UVB	UVB STABILIZED NYLON (RMS-46)	BLACK	NONE
FTH-5A-RT-UVB			ACRYLIC TAPE (RMS-15), WHITE LINER
*FTH-5A1-RT-UVB			RUBBER TAPE (RMS-102), BLUE LINER

\*AVAILABLE BY SPECIAL ORDER ONLY

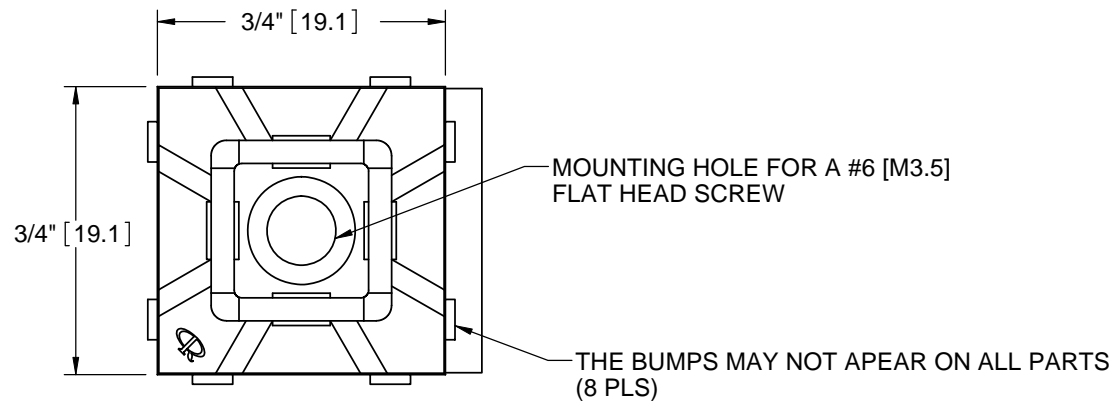

ACCOMODATES  
WIT-18, WIT-30, AND QTE-18 TIES

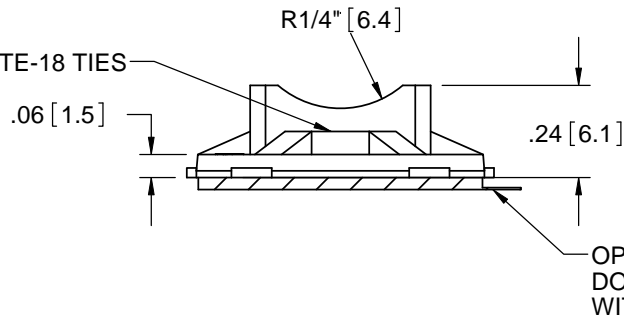

NOTES:  
1. MATERIAL: FLAME RETARDANT NYLON 6/6 (RMS-19)  
COLOR NATURAL.  
AVAILABLE BY SPECIAL ORDER ONLY.

REV.			TITLE: FLAT TIE HOLDER				DWG IN IN [MM]		FINAL	
H	SEE CO 200248 FOR CHANGES	SK	10/30/08	FILE #: FTH-5	DWN: SK	APP: -	PART #		PRINT TYPE	
G	SEE ECN #1124 FOR CHANGES	SK	01/24/06	SHEET: 1 OF 1	SHEET SIZE: A	DT: 03/10/05	CHKD: -	SEE TABLE	CA	
F	SEE ECN #962 FOR CHANGES	SK	03/10/05	RE: RICHCO, INC.	RICHCO, INC. ENG@RICHCO-INC.COM (773) 539-4060					
-	SEE ENGINEERING FOR REV. A-E	-	----	TOLERANCES UNLESS NOTED .XX=±.010 .XXX=±.005 FRAC.=±1/64 ANG.=±1°						
REV.	DESCRIPTION	ENGR.	DATE							